

## TYPE 92 302 A÷F

The signal device meets the following regulations:

**ICAO Annex 14, Volume I, 4th edition 2004 (Photometric requirements)**

**FAA Specification AC 150/5345-46C (Resistance against environmental effects)**



## Basic Information

The signal device design makes it resistant against static and dynamic effects of the ambient environment it is exposed to during the operation.

The base of all the signal device variants is a semi-spherical glass dioptré with a metallic housing into which is, depending on the signal device use, inserted a **variable optical unit** with a bulb, a lens, and a colour filter. Metallic parts of the signal device are made of anticorrosive materials. Powder coating in the "aerial yellow" tint protects the signal device. To make it more distinctive, the signal device may be furnished with an aluminium cone protected with the same colour powder coating.

The **92 302 E** variant with the red filter and the 200 W bulb fed with 24 V can be used as an obstacle signal device with a low luminosity in the A layout (ICAO Annex 14, Volume I, 3<sup>rd</sup> edition 1999).

## Technical Diagram

- 1 - Dioptré
- 2 - Bulb
- 6 - Optical unit
- 7 - Silicone ring
- 8 - Circle
- 9 - Body set
- 10 - Clamp
- 11 - Clamp
- 12 - Spring
- 13 - Pin
- 14 - Flexo
- 15 - Tube

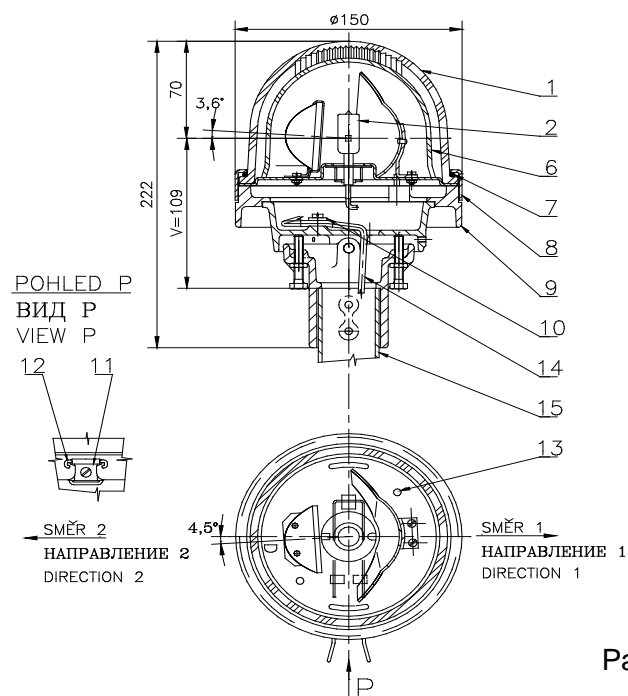

### Use

This signal device is used for luminous marking of runway and rolling systems of airports and heliports in the following variants:

	Use	Colour	Curve ICAO	Bulb Input		
				HRJF	OSRAM PHILIPS	
A	Airport	Lateral TWY	Blue	-	45 W	45 W
B,C		Lateral RWY	Yellow	2.9 2.10	200 W	150 W
B,C		Lateral RWY	White	2.9 2.10	200 W	150 W
D		Terminal RWY	Red	2.8	100 W	100 W
E	Heliport	Landing and Taking-off	Yellow	5-9 III.6	100 W	100 W
E		Final Rolling	White	5-9 III.5	200 W	200 W
F		Rolling	White	5-9 III 2	200 W	200 W

### Installation

The signal device may be installed directly into the ground on a tilting needle, or fixed to the cover.

#### Installation example:

- 1 – Signal device
- 2 – Tube
- 3 – Breakable coupling
- 4 – Concrete (asphalt) protective circle
- 5 – Insulation transformer
- 6 – Concrete for anchoring the needle
- 7 – Tilting needle

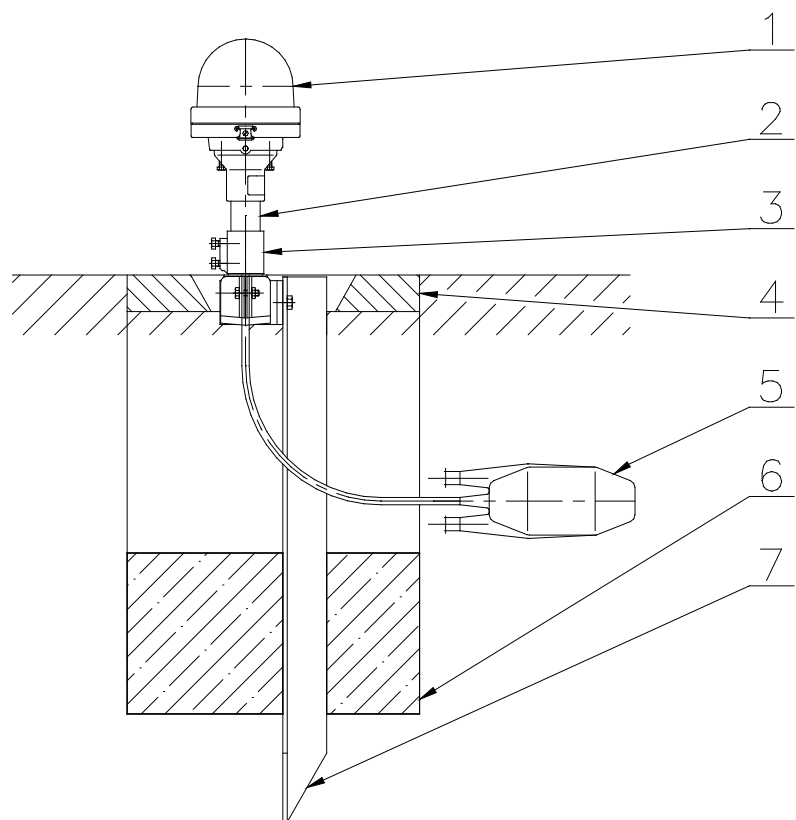

### Photometric Data

Luminosity curves:

1. 92,302 C  
(white, 200 W) 2.9

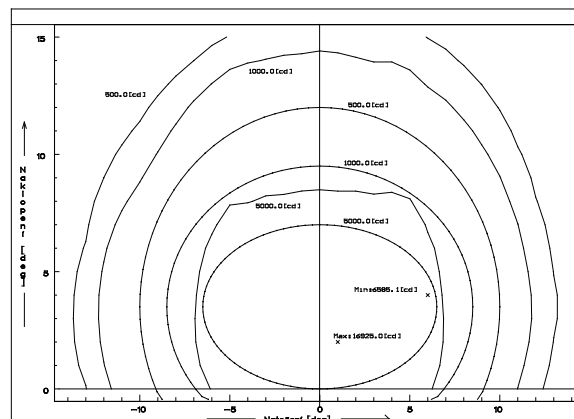

## Photometric Data

### 2. Horizontal section 92 302 F (white, 200 W)

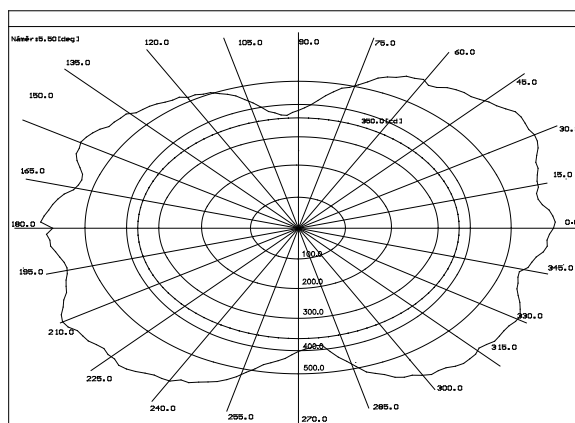

### 3. Vertical section 92 302 F (white, 200 W)

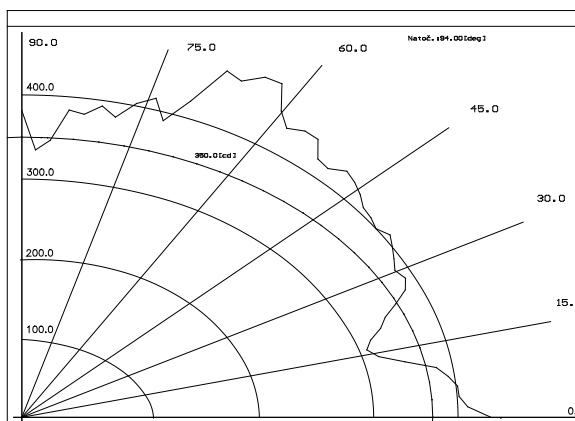

## Basic Technical Data

### Mechanical Parameters:

Dimensions (DxH): 150x190 up to 218 mm as per variant (w/o tube)

Mass: 1.2 up to 2.5 kg as per variant

### Electrical Parameters:

Input: As per the use

Current: 6.6 A

Insulation resistance: Min. 50 MΩ

Protection level: IP54

Luminous source used: Airport halide bulb  
As per use, Pk30d

### Other Parameters:

Operation temperature: -55°C up to +55°C

## Contact

### ELTODO EG, a.s.

Novodvorská 1010/14  
142 01 Praha 4, Czech Republic

Phone: +420 261 346 828

Fax: +420 261 346 803

E-mail: [eltodo@eltodo.cz](mailto:eltodo@eltodo.cz)

<http://www.eltodo.cz>